

Ultra Stack and Hang Bins

24 hour
FAST SHIPPING

Ultra Stack and Hang Bins

Organize your inventory with strong injection molded plastic bins. Front, back and side grips for easy handling. Built in rear hanger allows bins to hang from louvered panels. Optional clear plastic window increases capacity, provides quick view of contents. Dividers maximize flexibility and keep contents organized. Wide stacking ledge and anti-slide lock keep stacked bins steady and prevent forward shifting. Waterproof bins resist rust and corrosion. Large molded slots for ID labels. Autoclavable up to 250°F and resistant to extreme cold. Available in Blue, Yellow, Red, Green, Ivory and Black. Please specify color.



PERFORMANCE FEATURES AT A GLANCE:

- Available in 17 sizes
- Bins are made from heavy duty, virgin, high density FDA approved polypropylene / polyethylene
- Large multiple label slots provide easy label insertion and part identification
- Extra wide stacking ledge assures stability for high stacking
- Reinforced design adds strength and prevents spreading
- Will not rust or corrode, unaffected by weak acids and alkalis, and are waterproof
- Interchangeable with other manufactured brands of bins



QUS 233

can be used with either length or cross dividers.

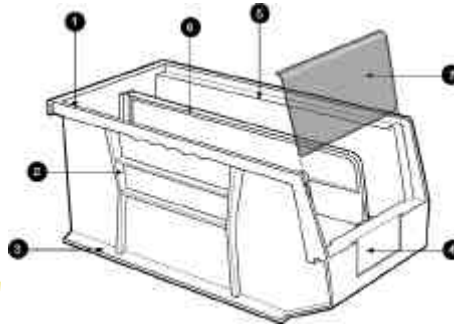
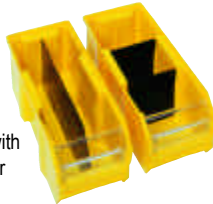

1. Full width hanger supports bin when hanging from louvered panels or rails.
2. Reinforced rib design adds strength and prevents spreading.
3. Extra-wide stacking ledge for secure stacking.
4. Large front label slot allows larger bar code scanning and content identification.
5. Anti-slide stop prevents stacked bins from shifting forward.
6. Optional dividers increase storage options.
7. Optional windows maximize storage capacity, prevent spillage and protects parts from dust and dirt.



MODEL NO.	OUTSIDE DIMENSIONS L" x W" x H"	CTN QTY	CTN WGT	PRICE EACH	CLEAR WINDOW	CTN QTY	PRICE EACH	DIVIDERS	CTN QTY	PRICE EACH
QUS 205	4-1/2" x 4-1/8" x 3"	24	5 lbs	\$0.64	-	-	-	DUS 205	6	\$0.45
QUS 210	5-1/2" x 4-1/8" x 3"	24	6 lbs	\$0.66	-	-	-	DUS 210	6	\$0.46
QUS 220	7-1/2" x 4-1/8" x 3"	24	7 lbs	\$1.07	-	-	-	DUS 220	6	\$0.51
QUS 224	10-7/8" x 4-1/8" x 4"	12	10 lbs	\$1.57	WUS 224	12	\$0.53	DUS 224	6	\$0.67
QUS 230	10-7/8" x 5-1/2" x 5"	12	11 lbs	\$2.69	WUS 230	12	\$0.54	DUS 230	6	\$0.76
QUS 233	13-1/2" x 5-1/2" x 5"	12	13 lbs	\$3.30	WUS 233	12	\$0.54	DUS 233 CDUS 233*	6 6	\$0.81 \$0.51
QUS 234	14-3/4" x 5-1/2" x 5"	12	14 lbs	\$3.40	WUS 234	12	\$0.55	DUS 234	6	\$0.84
QUS 235	11" x 11" x 5"	6	10 lbs	\$4.31	WUS 235	6	\$0.78	DUS 235	6	\$0.76
QUS 239	11" x 8-1/4" x 7"	6	10 lbs	\$4.64	WUS 239	6	\$0.70	DUS 239	6	\$0.96
QUS 240	14-3/4" x 8-1/4" x 7"	12	24 lbs	\$4.94	WUS 240	12	\$0.70	DUS 240	6	\$1.18
QUS 245	11" x 16-1/2" x 5"	6	18 lbs	\$6.21	WUS 245	6	\$1.54	DUS 245	6	\$0.76
QUS 250	14-3/4" x 16-1/2" x 7"	6	21 lbs	\$7.91	WUS 250	6	\$1.55	DUS 250	6	\$1.18
QUS 255	16" x 11" x 8"	4	14 lbs	\$7.60	WUS 255	4	\$1.28	DUS 255	6	\$2.18
QUS 260	18" x 11" x 10"	4	15 lbs	\$10.39	WUS 260	4	\$1.30	DUS 260	6	\$2.34
QUS 265	18" x 8-1/4" x 9"	6	17 lbs	\$8.94	WUS 265	6	\$1.22	DUS 265	6	\$2.03
QUS 270	18" x 16-1/2" x 11"	3	16 lbs	\$13.96	WUS 270	3	\$1.85	DUS 270	6	\$2.34
QUS 280	19-3/4" x 12-3/8" x 5-7/8"	6	17 lbs	\$9.19	WUS 280	6	\$1.69	DUS 280	6	\$2.21

* Indicates cross divider.

Labels are available for all Ultra Bins. For model no., substitute "L" for "Q" in bin model no. Ctn Qty: 50 labels Price per ctn: \$4.48